



Bathroom Booster

Team 14, 2023: Sawyer Masselink, Claire Sheppard, Caleb Styf, Jordan Tuter
Calvin University, Grand Rapids, Michigan

Introduction

The Bathroom Booster is a power assisted toilet seat lift that is designed to aid in the raising and lowering of an elderly person, with limited mobility, from a toilet seat in a residential space. This allows for easier and safer use of the bathroom without sacrificing their right to privacy and comfort. The project idea came forth from personal experience that each team member has with an older relative or someone they know who suffers from geriatric issues and a lack of mobility. As a person gets older, their muscles naturally degenerate and weaken. As a result, there is a constant battle between the values of safety and privacy. The Bathroom Booster will address this problem and allow for both values to be maintained in the intimate environment that is the bathroom, as well as fitting within standard bathroom specifications.

CAD Model

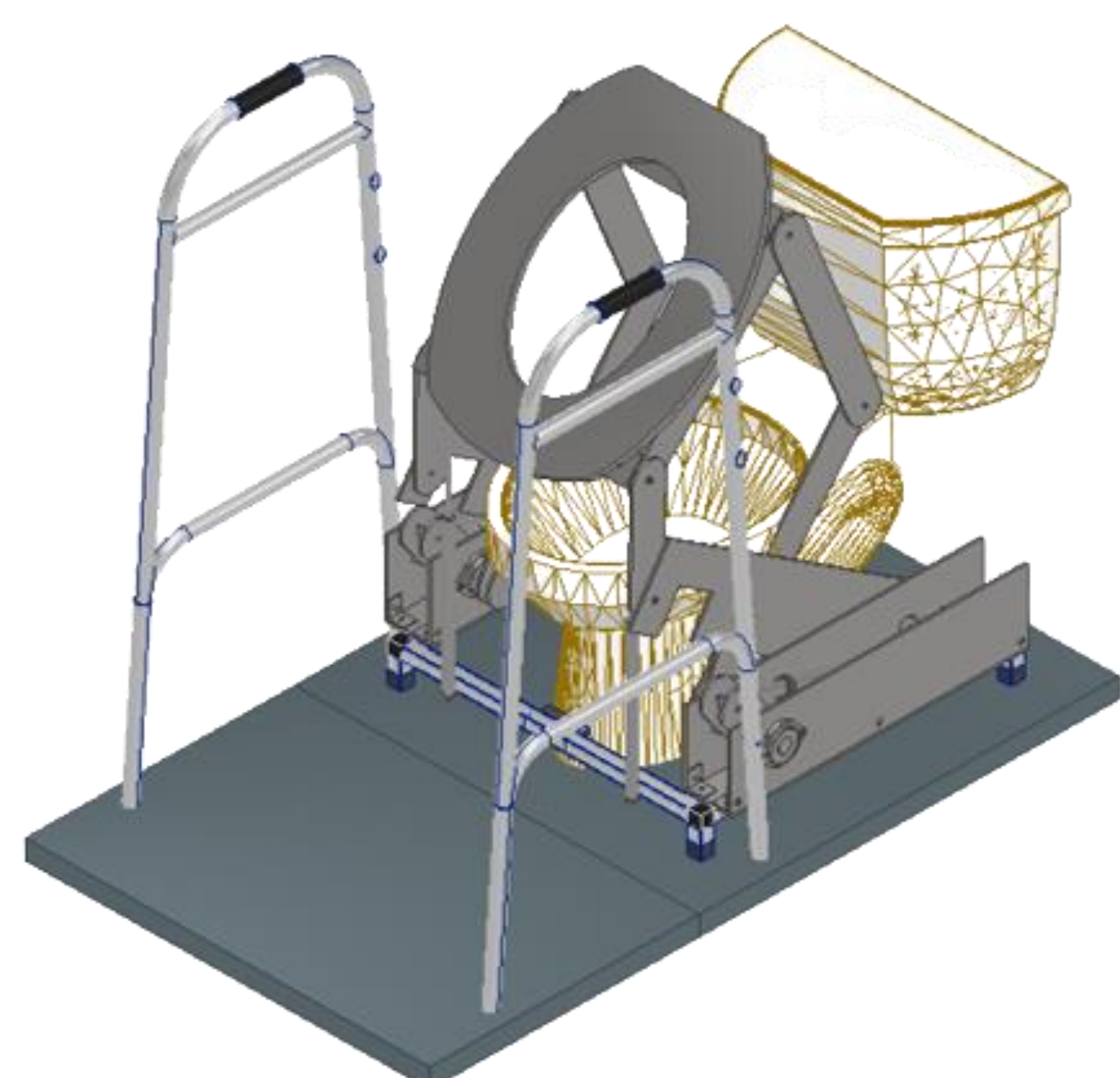

Methods

Research

The design of the Bathroom Booster was inspired from multiple sources, including existing toilet seat lifts and lift-assist recliners. Another source was a design showcased in an IEEE conference paper, which demonstrated a lift-assist chair with a combination of linear actuators and four-bar linkages.

Material Selection

A wooden prototype was constructed to measure how the linkages move. Cold rolled steel was chosen for the final linkages due to its high tensile strength. Aluminum was chosen for the base frame as it is compatible with nylon connectors, as well as the walker support frame.

Finite Element Analysis

This process allows us to apply loads to the model and display how the system will deform based on the given material strength. The model below displays minimal deformation of the device when loads are applied and instilled confidence in the final design.

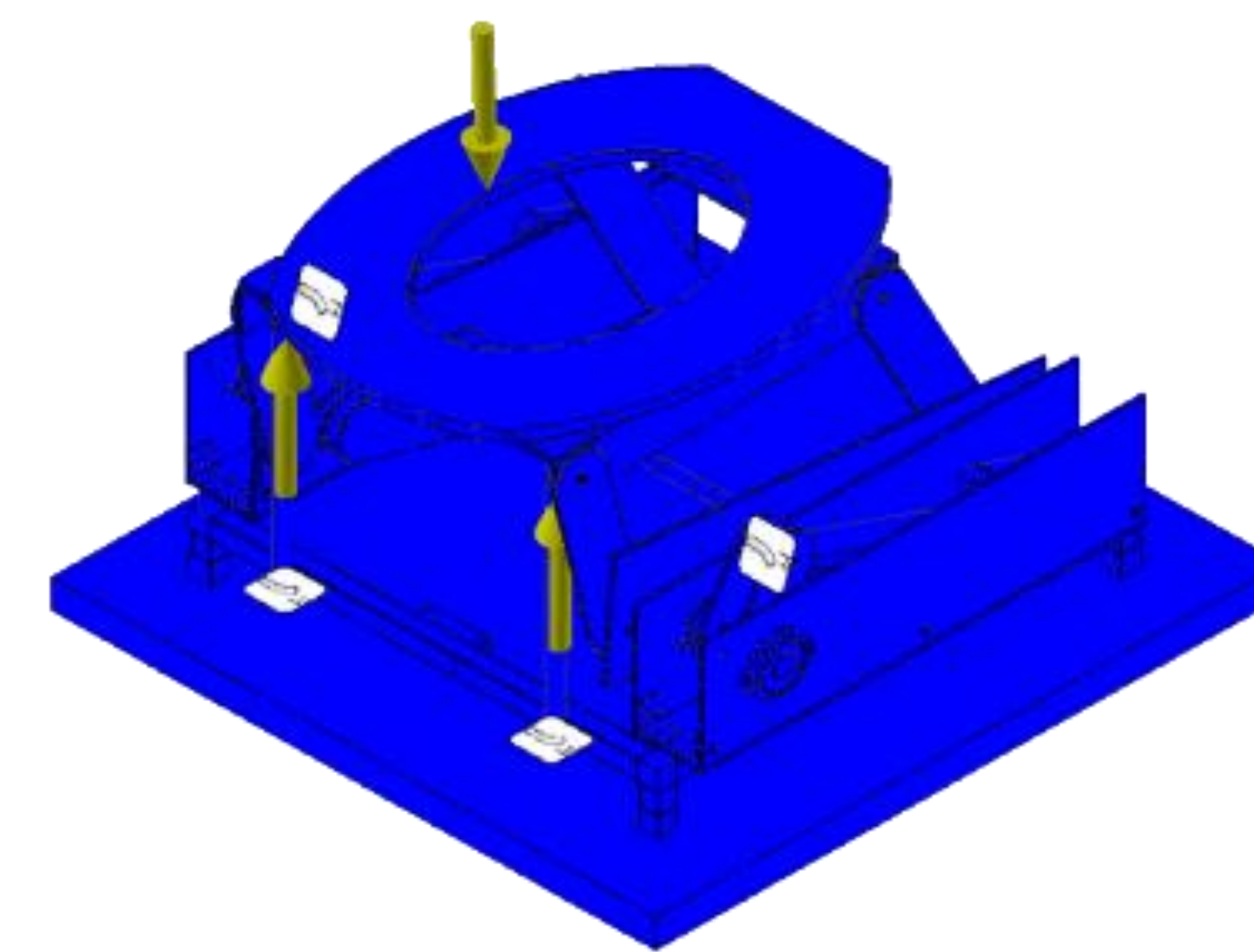

Final Design

The final design of the Bathroom Booster used multiple four-bar linkages driven by linear actuators. This has reduced the required size and strength of the linear actuators. Using a battery powered remote, the product can raise and lower in a timely manner, allowing for ease of use by the consumer. The project also finished significantly under budget, along with meeting our load and time requirements.



The Team



From Left to Right: Jordan Tuter (ME), Caleb Styf (ME), Claire Sheppard (ME), Sawyer Masselink (ME)

Acknowledgements

The team would like to thank and acknowledge those that offered support and contributed to our solution:

- Renard Tubergen** - Project Advisor
- Chris Sorenson** - Machine Shop Supervisor
- John Sparks** - Ergonomics Consultant
- Matthew Styf** - Doctor of Physical Therapy
- Hieyong Jeong** - IEEE Paper Author
- Harbor Steel** - Donation of Sheet Metal
- Calvin Machine Shop** - Donation of Tubing