



Team 13 – RailCARD

Ryan Whitney, Anika Huizinga, Drew Stoneburner, Chris Singh
Calvin University



THE PROBLEM

Transportation makes up roughly 35% of annual carbon emissions. Although electric cars have seen a rise in popularity, other transportation sectors have not integrated electric means. There are some applications currently used in the form of Maglev trains and electromagnetic aircraft launch systems (EMALS), but these are not as prevalent as they could be.

Maglev trains and EMALS both use linear motors to send vehicles down a track. A linear motor is an electric motor that creates a magnetic field to provide a force in a straight line. The linear motor accelerates the maglev trains until they reach the velocity to where they can be lifted off the track. The EMALS accelerates airplanes off the short flight deck, so they have enough speed to generate lift. While these applications are already used, there are only 6 commercial maglev trains operating in the world and a handful of EMALS. Expanding the application of electric transportation can help further reduce carbon emissions from fossil fuels and internal combustion engines.



The goal for this project is to create a linear motor that can be scaled for transportation purposes.



THE DESIGN

The linear motor consists of 4 pairs of hand wrapped coils: tightly wrapped wire around iron a core. These coils were mounted along the straightaway of the track. Hall effect sensors were mounted before the coils to detect the incoming car.

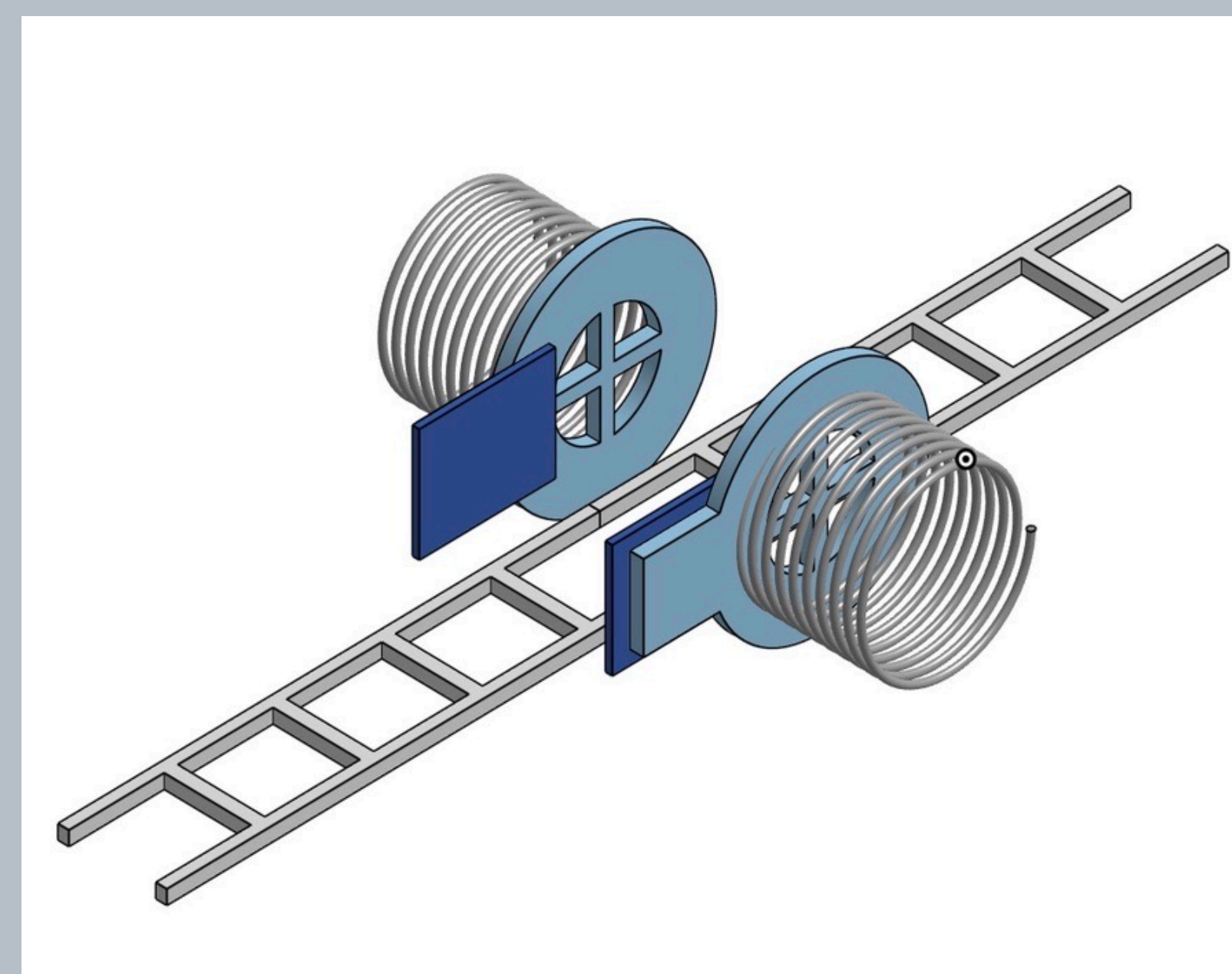

An Arduino controlled the timing and polarity of the discharged current to the coils.

The linear motor uses pairs of coils to generate magnetic fields that propel the vessel down the track. Hall effect sensors detect the presence of the incoming cart and send a signal is sent to an Arduino to turn on the coils for a tenth of a second. An H bridge switches the polarity of the coil before turning them back on. This allows the coil to pull the cart as it approaches the coil and then push it as it passes the coil. There These coils are on a straightaway that accelerate the cart through the rest of the track.

THE SOLUTION

Linear Motor Specs

The linear motor has 8 total coils that are placed in pairs. Each pair of coils has the potential to produce about 50 N of force with the current power supply.

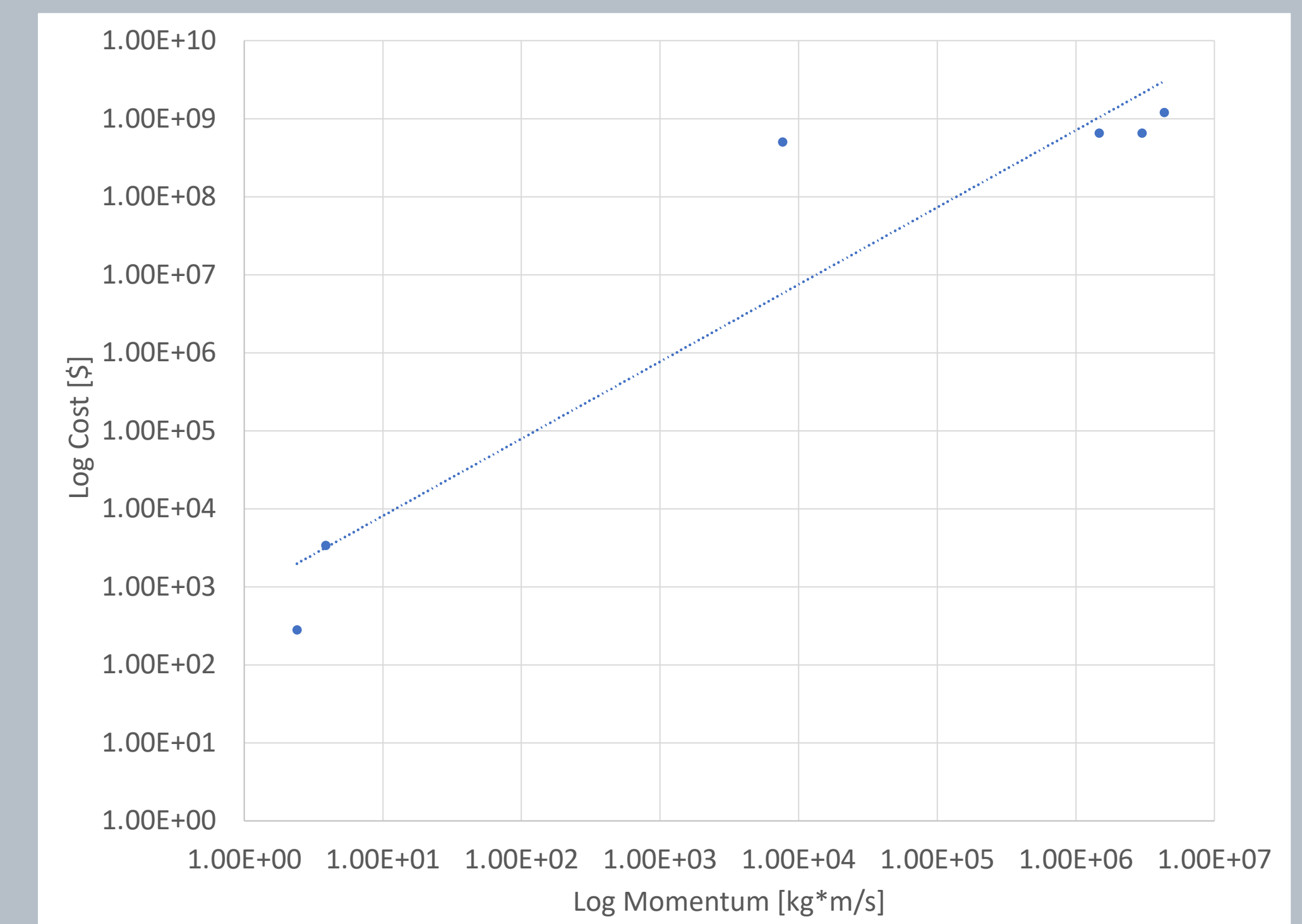

The cost model generated show a power model regression, so as required momentum increases, the cost of the linear motor and related infrastructure increases significantly.

Overall, producing the linear motor is possible but the price tag on it is the biggest drawback. It is very practical and competes with combustion engines, but the larger the application, the more it will cost to produce. While it is practical now, advancements in technology will make linear motors more economically viable in the future.